

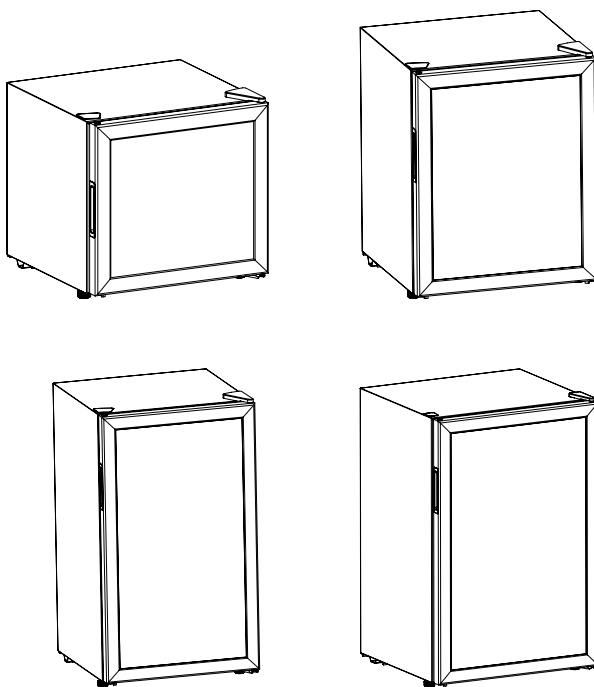

Beverage Cooler User Manual



MODEL
CCB51GB, CCB81GB, CCB109GB, CCB138GB

CONTENTS

SAFETY INFORMATION

Important Safety Instructions.....	3
Refrigerant	4
Grounding Instructions.....	4-5

SET UP & USE

Parts & Features	6
Installation Guide	9
Reversing the Door Hinge	10-12
Operation Instructions.....	13

CLEANING & CARE.....	14-15
----------------------	-------

TROUBLESHOOTING & WARRANTY

Before You Call For Service.....	16
Customer Service.....	16
Troubleshooting.....	17
Limited Warranty.....	18

PRODUCT REGISTRATION

Thank you for purchasing our
COMMERCIAL COOL product.
This easy-to-use manual will guide
you in getting the best use of your
Beverage Cooler.

Remember to record the model and
serial numbers. They are on a label
on the rear.

Model number

Serial number

Date of purchase

Staple your receipt to your manual.
You will need it to obtain warranty service.

SAFETY INFORMATION

DANGER

DANGER - Immediate hazards which **WILL** result in severe personal injury or death

WARNING

WARNING - Hazards or unsafe practices which **COULD** result in severe personal injury or death

CAUTION

CAUTION - Hazards or unsafe practices which **COULD** result in minor personal injury

IMPORTANT SAFETY INSTRUCTIONS

WARNING

When using electrical appliances, basic safety precautions should be followed, including the following:

READ ALL INSTRUCTIONS BEFORE USING THE UNIT

NOTE: If the Beverage Cooler has been placed in a horizontal or tilted position for any period of time, wait 24 hours before plugging the unit in.

1. Use this appliance only for its intended purpose as described in this use and care guide.
2. This Beverage Cooler must be properly installed in accordance with the installation instructions before it is used. See grounding instructions in the installation section.
3. Never unplug the Beverage Cooler by pulling on the power cord. Always grasp the plug firmly and pull straight out from the outlet.
4. Do not operate any appliance with a damaged cord or plug. Return appliance to the nearest authorized service facility for examination, repair or adjustment.
5. Unplug the Beverage Cooler before cleaning or before making any repairs. **NOTE:** If for any reason this product requires service, we strongly recommend that a certified technician performs the service.
6. This Beverage Cooler should not be recessed or built-in in an enclosed cabinet. It is designed for freestanding installation only.
7. Do not operate your Beverage Cooler in the presence of flammable or explosive fumes.

SAFETY INFORMATION

SAVE THESE INSTRUCTIONS





HOUSEHOLD USE ONLY

DANGER

Risk of child entrapment. Before disposing of any refrigerator or freezer, remove all doors. Leave any shelves in place so that children may not easily climb inside.

REFRIGERANT

GAS WARNINGS

-  **DANGER** - Risk of fire or explosion. Flammable refrigerant used. DO NOT use mechanical devices to defrost refrigerator. DO NOT puncture refrigerant tubing.
-  **DANGER** - Risk of fire or explosion. Flammable refrigerant used. To be repaired only by trained service personnel. DO NOT puncture refrigerant tubing.
-  **WARNING** - Risk of fire or explosion. Flammable refrigerant used. Consult repair manual/owner's guide before attempting to service this product. All safety precautions must be followed.
-  **WARNING** - Risk of fire or explosion. Dispose of properly in accordance with federal or local regulations. Flammable refrigerant used.
-  **WARNING** - Risk of fire or explosion due to puncture of refrigerant tubing; Follow handling instructions carefully. Flammable refrigerant used.

GROUNDING INSTRUCTIONS

ELECTRICAL REQUIREMENTS

In the event of malfunction or breakdown, grounding provides a path of least resistance for electric current to reduce the risk of electric shock. The appliance must be connected to a cord having an equipment-grounding conductor and a grounding plug. The plug must be plugged into an appropriate outlet that is properly installed and grounded in accordance with all local codes and ordinances.

SAFETY INFORMATION

⚠ DANGER - Improper connection of the equipment grounding conductor can result in a risk of electric shock. The grounding conductor is insulated and features an outer green surface with or without yellow stripes. If repair or replacement of the cord or plug is necessary, do not connect the equipment-grounding conductor to a live terminal. Check with a qualified electrician or service person if the grounding instructions are not completely understood, or if in doubt as to whether the appliance is properly grounded. Do not modify the plug if it will not fit the outlet, have a proper outlet installed by a qualified electrician.

The appliance is for use on a nominal 120V circuit and should be connected to a grounding outlet that looks like the one illustrated below. The use of a temporary adaptor is not recommended.

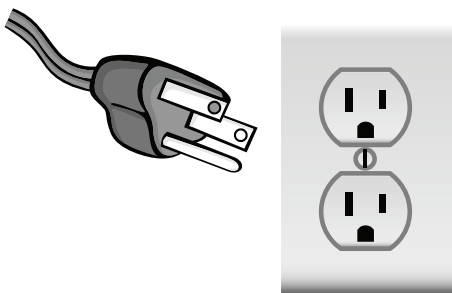

POWER SUPPLY CORD

1. Avoid the use of an extension cord because of potential safety hazards under certain conditions. Have a qualified electrician or serviceman install an outlet near the appliance.
2. If it is absolutely necessary to use an extension cord, extreme care must be exercised.
 - a) Use only a grounding type 3-wire extension cord that has a 3-blade grounding plug and a 3-slot receptacle that will accept the plug on the appliance.
 - b) The marked electrical rating of the extension cord must equal to or greater than the electrical rating of the appliance. The longer cord should be arranged so that it will not drape over the counter top or table top where it can be pulled on by children or tripped over unintentionally.

NOTE: Neither COMMERCIAL COOL nor the dealer can accept any liability for damage to the product or personal injury resulting from failure to observe the electrical connection procedures.

SET UP & USE

PARTS & FEATURES

MODEL CCB51GB

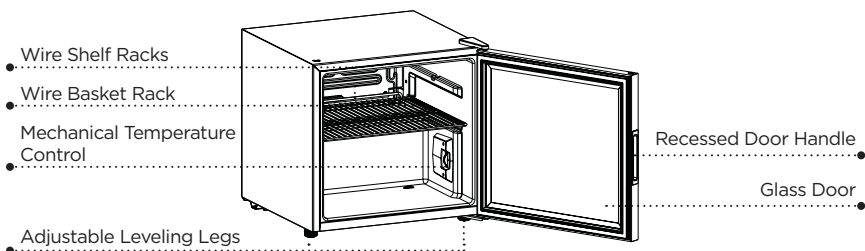

MODEL CCB81GB

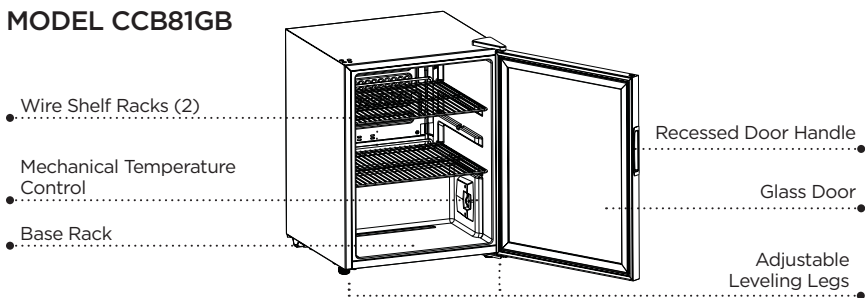

MODEL CCB109GB

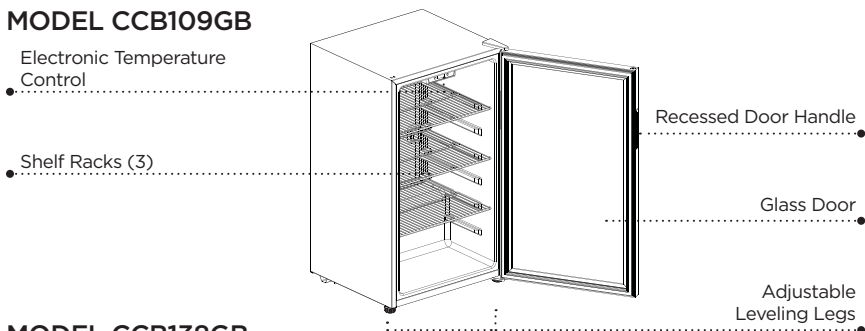

MODEL CCB138GB

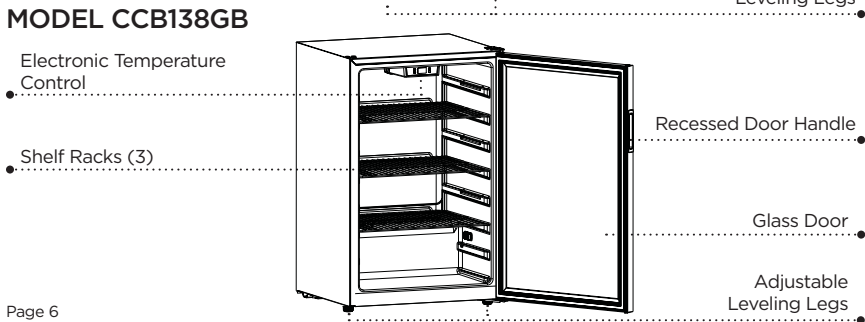

SET UP & USE

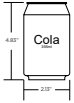

12 oz. Can
Height: 4.83"
Diameter: 2.13"

MODEL: CCB51GB 1.7 Cu. Ft.

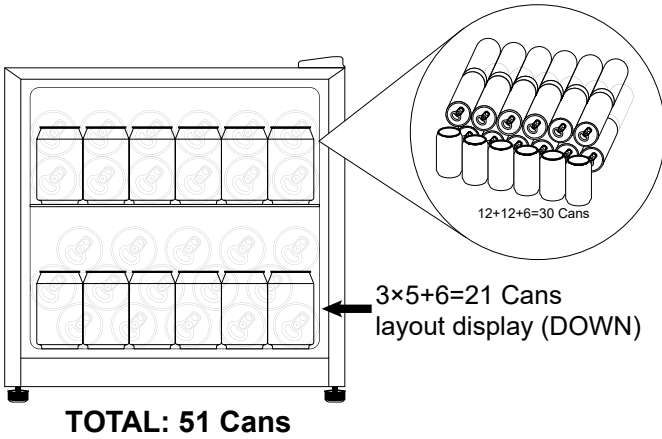

MODEL: CCB81GB 2.7 Cu. Ft.

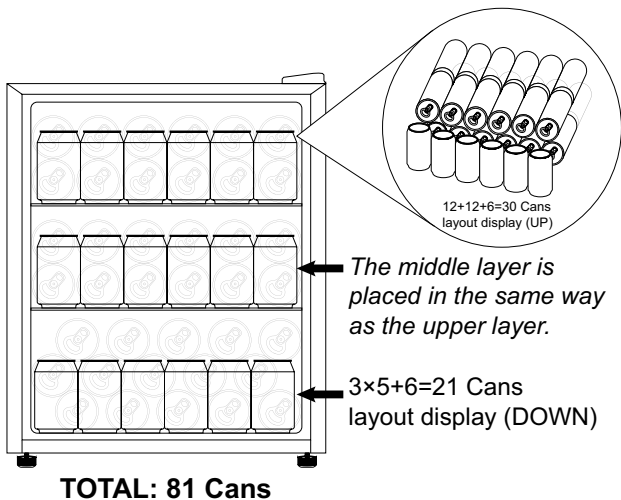

SET UP & USE



12 oz. Can
Height: 4.83"
Diameter: 2.13"

MODEL: CCB109GB 3.6 Cu. Ft.

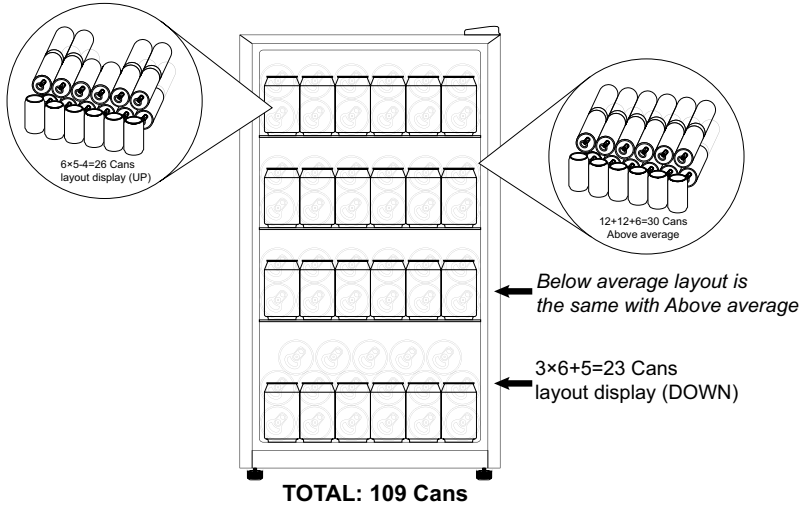

MODEL: CCB138GB 4.4 Cu. Ft.

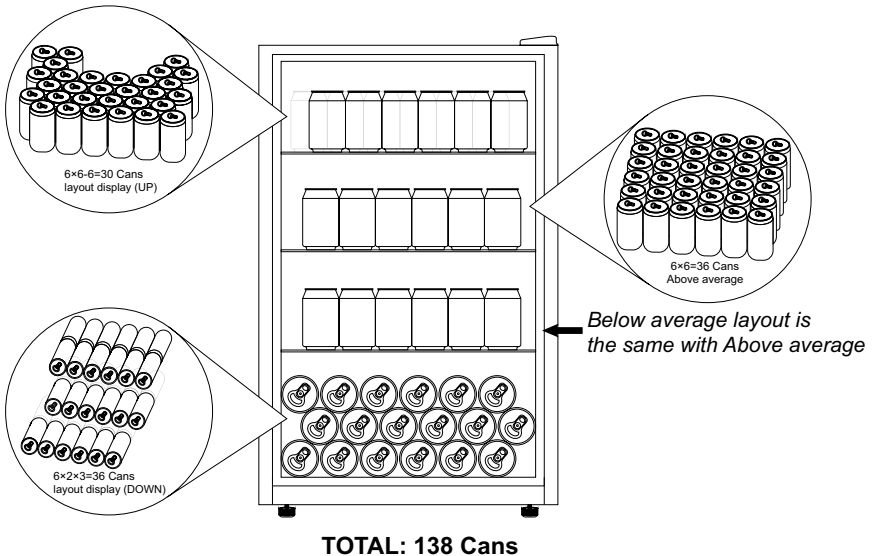

SET UP & USE

INSTALLATION GUIDE

1. Unpack your Beverage Cooler by removing all packaging materials like carton, base, foams, adhesive tape, etc.
2. Remove all accessories, internal packaging material that was used to hold shelves, etc., in place during transport.
3. Clean the remains of all adhesive tape used and remove all printed material supplied.
4. Install the Beverage Cooler in a convenient location away from extreme heat and cold. Allow sufficient clearance between the Beverage Cooler and side wall so the door(s) will open without obstruction. Beverage Cooler is not designed for recessed installation.
5. The floor on which the Beverage Cooler should be placed must be flat, hard, solid, and even. The Beverage Cooler should not be placed on any soft material such as carpeting, foam, plastic, etc.
6. To level your Beverage Cooler, use the two leveling legs located on the bottom front of your Beverage Cooler. Adjust by turning the legs counterclockwise to raise or clockwise to lower your Beverage Cooler. The door will close easier if the leveling legs are extended.
7. The following is the recommended minimum clearance around the Beverage Cooler for proper air circulation:
Sides: 2" (50mm)
Top: 2" (50mm)

Proper air circulation will help your Beverage Cooler work at maximum efficiency.

NOTE: The appliance must be correctly connected to the power supply.

WARNING

It is important to keep the power cord away from the compressor at the rear of the Beverage Cooler during operation, the compressor can reach a high temperature and could cause serious damage to the power cord.

CAUTION

Care should be taken during handling, moving and use to avoid damaging the refrigerant tubing or increasing the risk of a leak.

SET UP & USE

PROTECTION FROM HEAT AND MOISTURE

- Do not install your Beverage Cooler in any location where heavy moisture is present or if the location is not properly insulated. This Beverage Cooler is not designed to operate in temperature settings below 55° Fahrenheit.
- Location for the Beverage Cooler should be on a hard surface and away from direct sunlight and heat source, e.g., radiators, baseboard heaters, cooking appliances, etc.

REVERSING THE DOOR HINGE

(MODEL CCB51GB & CCB81GB)

1. Remove the top hinge cover.
2. Using a Phillips Head Screwdriver, loosen and remove the 2 screws holding the top hinge in place.
3. Remove top hinge and carefully lift off the door.
4. Remove the screw hole plugs from the opposite side of the cabinet and the door and insert the plugs in the screw hole openings of the just removed screws.
5. Remove any loose items in the Beverage Cooler.
NOTE: Do not tilt the appliance over 45 degrees when reversing the door as possible damage to the sealed system may occur.
6. Remove Left & Right Leveling Feet from underside of Cooler.
7. Loosen the screws holding the lower hinge bracket to the Beverage Cooler and remove screws and bracket.
8. Remove the door pin from the lower hinge bracket by turning it counterclockwise.
9. Remove (2) screws from the opposite side of the Cooler and insert these screws into the previously removed screw holes. Tighten the screws.
10. Flip the lower bracket over and then reinsert the door pin into the threaded hole and tighten.
11. Align the door with the cabinet first. Then install the lower hinge bracket to your desired side of the cabinet. Make sure door is resting on door pin of the lower bracket. Then insert (2) remaining screws into the holes. Tighten the screws.
12. Align top hinge bracket with screw holes, insert screws and partially secure, check that door and cabinet are properly aligned and then secure tightly.

SET UP & USE

13. Replace the top hinge cover and leveling feet. Adjust leveling feet as necessary.

NOTE: If the top of the door is not aligned with the cabinet, loosen the top hinge screws, adjust door and re-tighten the screws.

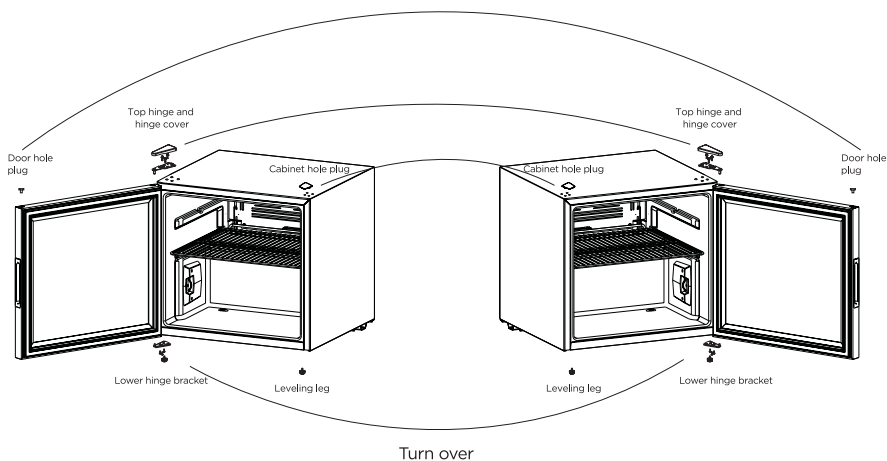

REVERSING THE DOOR HINGE (MODEL CCB109GB & CCB138GB)

1. Remove the top hinge cover.
2. Using a Phillips Head Screwdriver, loosen and remove the 2 screws holding the top hinge in place.
3. Remove top hinge and carefully lift off the door.
4. Remove the screw hole plugs from the opposite side of the Cabinet and the Door and insert the plugs in the screw hole openings of the just removed screws.
5. Remove any loose items in the Beverage Cooler.
NOTE: Do not tilt the appliance over 45 degrees when reversing the door as possible damage to the sealed system may occur.
6. Remove Leveling Leg from underside of Cooler.
7. Loosen the screws holding the lower hinge bracket to the Beverage Cooler and remove screws and bracket.

SET UP & USE

8. Remove cabinet screw and door plug from opposite side and insert into the holes previously used by the door.
9. Remove the door pin from the lower hinge bracket by turning it counterclockwise, then reinsert it into the neighboring treaded hole and tighten.
10. Align the door with the cabinet first. Then install the lower hinge bracket to the bottom opposite side of the cabinet. Make sure door is resting on door pin of the lower bracket. Then insert (2) remaining screws into the holes. Tighten the screws.
11. Align top hinge bracket with screw holes, insert screws and partially secure, check that door and cabinet are properly aligned and then secure tightly.

NOTE: If the top of the door is not aligned with the cabinet, loosen the top hinge screws, adjust door and re-tighten the screws.

12. Replace the Top Hinge Cover and Leveling Leg. Make sure Leveling Leg is installed to the opposite side of the door hinge. Adjust Leg as necessary.

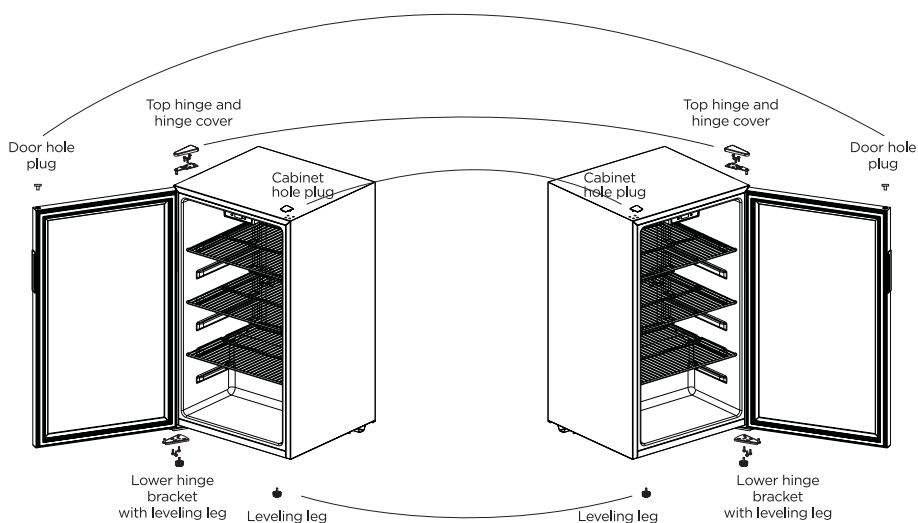

SET UP & USE

OPERATING INSTRUCTIONS

STARTING YOUR NEW BEVERAGE COOLER

After cleaning your Beverage Cooler thoroughly, Wipe the outside with a soft dry cloth and the interior with a clean moist cloth. Insert the power supply cord into the socket.

NOTE: If the Beverage Cooler has been placed in a horizontal or tilted position for any period of time, wait 24 hours before plugging the unit in.

TEMPERATURE CONTROL

CCB51GB and
CCB81GB

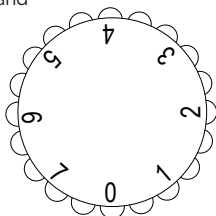

CCB109GB and
CCB138GB



- Turn the variable temperature control knob to the appropriate temperature for your beverages.
- The beverage cooler has a temperature range from 32°F to 64°F. Simply turn the dial to your preferred temperature setting.
- Turning the temperature to “0” position will shut off the cooling cycle, but does not turn off the electrical power to the unit.
- Operate the beverage center by adjusting the temperature control buttons (up and down arrows) to various settings. The adjusting temperature range is 32°F to 61°F (0°C to 16°C).
- Touch this pad once (▲) and the temperature will increase 1 °F (1 °C).
- Touch this pad once (▼) and the temperature will decrease 1 °F (1 °C).
- The new desired temperature will flash on the display for five seconds and then back to the actual temperature which will gradually change until the set point is reached.
- Touch this pad (°C/°F) and the temperature display will switch between °C & °F.

NOTE: Wait 3-5 minutes before restarting if you unplug the Beverage Cooler. The unit may fail to operate properly if restarted too quickly.

INTERIOR LIGHT (Only CCB109GB and CCB138GB have Interior Light)

You can turn the interior light ON or OFF by pressing “LIGHT” on the light switch located on the front of the control panel. To turn the light OFF press the switch again.

CLEANING AND CARE

CLEANING AND MAINTENANCE

WARNING

Always unplug appliance before cleaning to avoid electric shock. Ignoring this warning may result in death or injury

CAUTION

To avoid personal injury or product damage always read and follow manufacturer's instructions and warnings before using any cleaning products.

POWER INTERRUPTION

In case of a power interruption/ou tage, unplug the power cord from the wall outlet. Replug the power cord to the wall outlet once the power has been restored.

CLEANING METHOD

Prepare a cleaning solution of 3-4 tablespoons of baking soda mixed with warm water. Use sponge or soft cloth, dampened with the cleaning solution to wipe down your Beverage Cooler.

- Rinse with clean warm water and dry with a soft cloth.
- Do not use harsh chemicals, abrasives, ammonia, chlorine bleach, concentrated detergents, solvents or metal scouring pads. Some of these chemicals may dissolve, damage and/or discolor your Beverage Cooler.

CLEANING AND CARE

VACATION AND MOVING CARE

- For long vacations or absences, set the temperature dial to “OFF”, unplug the unit, empty contents from Beverage Cooler and clean the Beverage Cooler according to “General Cleaning” section. Prop doors open, so air can circulate inside.
- When traveling or moving the Beverage Cooler, always transport the unit vertically. Moving the unit on its sides may damage the Beverage Cooler and/or its compressor. **Do not move or store the unit on its side**

ENERGY SAVING TIPS

- The Beverage Cooler should be located in the coolest area of the room, away from heat-producing appliances or heating ducts, and out of direct sunlight.
- Overloading the Beverage Cooler forces the compressor to run longer and thus increase energy consumption.
- The shelves should not be lined with aluminum foil, wax paper, or paper towels. This will interfere with cold air circulation, making the Beverage Cooler less efficient.
- Organize beverages to reduce door openings and extended searches. Remove as many items as needed at one time, and close the door as soon as possible.

TROUBLESHOOTING & WARRANTY

BEFORE YOU CALL FOR SERVICE

IF THE APPLIANCE FAILS TO OPERATE:

- A) Check to make sure that the Beverage Cooler is plugged in securely. If it is not, remove the plug from the outlet, wait 10 seconds and plug it in again securely.
- B) Check for a blown circuit fuse or a tripped main circuit breaker. If these seem to be operating properly, test the outlet with another appliance.

IF NONE OF THE ABOVE SOLVES THE PROBLEM, CONTACT A QUALIFIED TECHNICIAN. DO NOT TRY TO ADJUST OR REPAIR THE APPLIANCE YOURSELF.

IMPORTANT

DO NOT RETURN THIS PRODUCT TO THE STORE

If you have a problem with this product, please contact the W Appliance CO. Customer Satisfaction Center at 844-299-0879 or service@equitybrands.com

**DATED PROOF OF PURCHASE, MODEL # AND SERIAL #
REQUIRED FOR WARRANTY SERVICE**

TROUBLESHOOTING & WARRANTY

Troubleshoot your problem by using the chart below. If the Beverage Cooler still does not work properly, contact COMMERCIAL COOL customer service center or the nearest authorized service center.

TROUBLE	POSSIBLE CAUSE	POSSIBLE REMEDY
Beverage Cooler does not work	<ul style="list-style-type: none"> • Beverage Cooler is not switched on • Unit is not plugged in • A household fuse has blown or circuit breaker has tripped • Wall power socket is defective 	<ul style="list-style-type: none"> • Turn on the temperature control dial. It may be in the OFF, "0" position • Plug in the Beverage Cooler • Replace the household fuse or reset circuit breaker • To be corrected by a qualified electrician
The beverage is too cold	<ul style="list-style-type: none"> • Temperature is not properly adjusted 	<ul style="list-style-type: none"> • Set the temperature control dial to a warmer setting
The beverage is too warm	<ul style="list-style-type: none"> • Temperature is not properly adjusted • Door was open for an extended period • A large quantity of beverages were placed in the Beverage Cooler within the last 24 hours • The Beverage Cooler is near a heat source 	<ul style="list-style-type: none"> • Set the temperature control dial to a cooler setting • Open the door only as long as necessary. Check door gasket for proper seal • Set the temperature control dial to a colder setting temporarily • Refer to "Protection From Heat and Moisture" section
Popping or cracking sounds	<ul style="list-style-type: none"> • When compressor comes on 	<ul style="list-style-type: none"> • This is a normal sound of coolant flowing through condenser coils
Beverage Cooler door does not shut properly	<ul style="list-style-type: none"> • The Beverage Cooler door is not properly aligned • Possible blockage from bottles shelves, bins, etc. 	<ul style="list-style-type: none"> • Re-align the Beverage Cooler door. Refer to the "Door Alignment" section • Ensure nothing is blocking the door
Beverage Cooler has an odor	<ul style="list-style-type: none"> • Interior needs cleaning 	<ul style="list-style-type: none"> • Please refer to "Cleaning and Care" section

LIMITED WARRANTY

Any repair, replacement, or warranty service, and all questions about this product should be directed to W Appliance Co. at **844-299-0879** from the USA or Puerto Rico.

W Appliance Co. warrants to the original purchaser that the product will be free from defects in material, parts and workmanship for the period designated for this product. The warranty commences the day the product is purchased and covers up to a period of **1 year (12 months) for labor/1 year (12 months) for parts (manufacturing defects only).**

W Appliance Co. agrees that it will, at its option, replace the defective product with either a new or remanufactured unit equivalent to your original purchase during the warranty period.

Exclusions: This warranty does not apply to the below:

1. If the appearance or exterior of the product has been damaged or defaced, altered or modified in design or construction.
2. If the product original serial number has been altered or removed or cannot be readily determined.
3. If there is damaged due to power line surge, user damage to the AC power cord or connection to improper voltage source.
4. If damage is due to general misuse, accidents or acts of God.
5. If repair attempts are done by unauthorized service agents, use of parts other than genuine parts or parts obtained from persons other than authorized service companies.
6. On units that have been transferred from the original owner.
7. On products that have been purchased as refurbished, like new, second-hand, in a "As-Is" or "Final Sale" terms.
8. To products used in a commercial or rental setting.
9. To products used in settings other than ordinary household use or used other than in accordance with the provided instructions.
10. To damages for service calls for improper installations.
11. Transportation and shipping costs associated with the replacement of the unit.
12. Service calls to instruct you how to use your product.
13. Service calls to repair or replace the house fuse, reset the circuit breaker or correct the wiring in the house.

REPAIR OR REPLACEMENT AS PROVIDED UNDER THIS WARRANTY IS THE EXCLUSIVE REMEDY OF THE CUSTOMER; W Appliance Co. SHALL NOT BE LIABLE FOR ANY INCIDENTAL OR CONSEQUENTIAL DAMAGES FOR BREACH OF ANY EXPRESS OR IMPLIED WARRANTY ON THIS PRODUCT, EXCEPT TO THE EXTENT PROHIBITED BY APPLICABLE LAW. ANY IMPLIED WARRANTY OF MERCHANTABILITY OF FITNESS FOR A PARTICULAR PURPOSE ON THIS PRODUCT IS LIMITED TO THE DURATION OF THE WARRANTY.

Some states do not allow the exclusion or limitations of incidental or consequential damages, or limitations on how long the warranty lasts. In these cases the above exclusions or limitations may not apply to you. This warranty gives you specific legal rights and you may also have other rights which vary from state to state.

Obtaining Service: To obtain service, product literature, supplies or accessories please call **844-299-0879** to create a ticket for exchange/repair. Please make sure to provide the date of purchase, model number and a brief description of the problem. Our customer service representative will contact you or send detailed return instructions.

W Appliance Co. does not warrant that the appliance will work properly in all environmental conditions, and makes no warranty and representation, either implied or expressed, with respect to the quality, performance, merchantability, or fitness for a particular purpose other than the purpose identified within this user's manual. W Appliance Co. has made every effort to ensure that this user's manual is accurate and disclaims liability for any inaccuracies or omissions that may have occurred. Information in this user's manual is subject to change without notice and does not represent a commitment on the part of W Appliance Co. W Appliance Co. reserves the right to make improvements to this user's manual and/or to the products described in this user's manual at any time without notice. If you find information in this manual that is incorrect, misleading, or incomplete, please contact us at **844-299-0879**.

W Appliance Co.
1356 Broadway
New York, NY 10018



© 2021 W Appliance Company. All Rights Reserved.
1356 Broadway, New York, NY 10018

April 2021